

K.W.

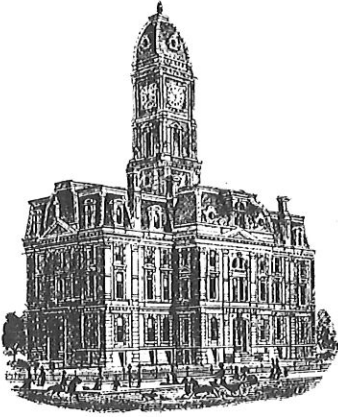

SURVEYOR'S OFFICE Hamilton County

Kenton C. Ward, CFM
Surveyor of Hamilton County
Phone (317) 776-8495
Fax (317) 776-9628

Suite 188
One Hamilton County Square
Noblesville, Indiana 46060-2230

August 6, 2021

TO: Hamilton County Drainage Board

RE: Little Eagle Creek, Alva Osborn Drain—Atwater

Attached is a petition and plans for the proposed reconstruction of the Alva Osborn Drain. The reconstruction is being proposed by Olthoff Homes. The proposal is one part of a three part plan to reconstruct the Alva Osborne, George Coverdale and Stephens and Clark Drains as a part of the master plan for the Atwater Subdivision. The reconstructions are per plans by HWC Engineering, having Job No. 2019-157-A and dated January 3, 2020.

The new system described in this report will intercept the George Coverdale and Alva Osborn Drains in the form of a new open ditch running from west to east and then south along the north and east limits of the Atwater Subdivision. An overview of the new ditch can be found on Sheet C1.16 labeled Emergency Flood Route.

The Reconstruction of the Alva Osborn Drain shall begin at the northern limits of the subdivision at Station 85+53 per the drains original 1914 description and at the proposed Structure 289 as shown on Sheets C1.18 and C6.5 in the above referenced plans. The drain then runs south for 26 feet with 60" RCP before outletting into the new open ditch at Structure 288 per the plans. This is located at Station 20+45 per the profile on Sheet C1.18 of the plans. The new open ditch then runs east for 255 feet before turning south at Station 23+00 of the profile and running for 666 feet before outletting into a box culvert at Station 29+66 which runs for 94 feet to Station 30+60 thence continuing as an open ditch another 334 feet before outletting into a culvert which will run beneath Six Points Road for 95 feet before outletting into the existing Alva Osborn Open Ditch as shown on Sheet C1.19 of the plans. The existing tile for the Alva Osborn Drain will be removed from Station 85+53 to Station 97+93 per the original 1914 Alva Osborn description. The entirety of the 1978/2002 SCS Outlet Reconstruction Arm at Six Points Road beginning at approximately Station 96+93 per the Alva Osborn original description and running south for 80 feet before emptying into an aluminum drop structure will also be reconstructed as part of this project.

The reconstructed drain shall consist of the following:

60" RCP	26 feet
72"x60" Box Culvert	94 feet

96"x72" Box Culvert	95 feet
Open Ditch	1,361 feet

The total length of the reconstructed drain was 1,576 feet. The proposal will increase the length of regulated drain by 436 feet.

The overall cost of reconstruction will be paid by Olthoff Homes.

The petitioner has provided the Performance Bond as follows:

Storm Sewers

Bonding Company:	Lexon Insurance Com
Bond Number:	LICX1196190
Bond Date:	October 27, 2020
Bond Amount:	\$586,964.40

Erosion Control

Bonding Company:	Lexon Insurance Com
Bond Number:	LICX1196191
Bond Date:	October 27, 2020
Bond Amount:	\$84,689.00

Two offsite easements have been granted with the reconstruction of the Alva Osborn Drain and are located on two separate parcels, parcel 08-05-22-00-00-020.000 owned by Carey & Son's, Inc. and parcel 08-05-22-00-00-020.001 owned by Steven M. & Linda L. Osborne. Prior to the hearing, the easement grants have been reviewed approved and Recorded Instrument Numbers 2021035342 and 2021035253 respectively.

I recommend that upon approval of the above proposed drain that the Board also approve the attached non-enforcement request. The non-enforcement is for the altering of the regulated drain easement widths as shown in the above referenced plans and secondary plat for Atwater.

I recommend that the Board set a hearing for this proposed drain for September 27, 2021.



Kenton C. Ward, CFM
Hamilton County Surveyor

KCW/pll

HAMILTON COUNTY DRAINAGE BOARD
NOBLESVILLE, INDIANA

FILED

OCT 20 2020

OFFICE OF HAMILTON COUNTY SURVEYOR

IN RE: Olthof Homes; Atwater Section 1)
Hamilton County, Indiana)

PETITION FOR RELOCATION AND RECONSTRUCTION

Ed Recktenwall (hereinafter "Petitioner"),
hereby petitions the Hamilton County Drainage Board for authority to relocate and improve a
section of the Alva Osborn Drain, and in support of
said petition advises the Board that:

1. Petitioner owns real estate through which a portion of the Alva Osborn Drain runs.
2. Petitioner plans to develop its real estate with roads, buildings, utilities, storm drains, sanitary sewers and other structures.
3. Petitioner's proposed development of its real estate will require relocation and reconstruction of a portion of the Alva Osborn Drain, as specifically shown on engineering plans and specifications filed with the Hamilton County Surveyor.
4. The work necessary for the proposed relocation and reconstruction will be undertaken at the sole expense of the Petitioner and such work will result in substantial improvement to the Alva Osborn Drain, without cost to other property owners on the watershed of the Alva Osborn Drain.

WHEREFORE, Petitioner requests that an Order issued from the Hamilton County Drainage Board authorizing relocation and reconstruction of the Alva Osborn Drain, in conformance with applicable law and plans and specifications on file with the Hamilton County Surveyor.

Edward Recktenwall
Signed

EDWARD Recktenwall
Printed

HAMILTON COUNTY DRAINAGE BOARD
NOBLESVILLE, INDIANA

FILED

NOV 02 2020

OFFICE OF HAMILTON COUNTY SURVEYOR

IN RE: Atwater Development LLC; Atwater Section 1)
Hamilton County, Indiana)

PETITION FOR RELOCATION AND RECONSTRUCTION

Atwater Development LLC (hereinafter Petitioner"),

hereby petitions the Hamilton County Drainage Board for authority to relocate and improve a section of the Alva Osborn Drain, and in support of said petition advises the Board that:

1. Petitioner owns real estate through which a portion of the Alva Osborn Drain runs.
2. Petitioner plans to develop its real estate with roads, buildings, utilities, storm drains, sanitary sewers and other structures.
3. Petitioner's proposed development of its real estate will require relocation and reconstruction of a portion of the Alva Osborn Drain, as specifically shown on engineering plans and specifications filed with the Hamilton County Surveyor.
4. The work necessary for the proposed relocation and reconstruction will be undertaken at the sole expense of the Petitioner and such work will result in substantial improvement to the Alva Osborn Drain, without cost to other property owners on the watershed of the Alva Osborn Drain.

WHEREFORE, Petitioner requests that an Order issued from the Hamilton County Drainage Board authorizing relocation and reconstruction of the Alva Osborn Drain, in conformance with applicable law and plans and specifications on file with the Hamilton County Surveyor.

Edward Redkwan
Signed

EDWARD Redkwan
Printed

FINDINGS AND ORDER

CONCERNING THE PARTIAL VACATION OF THE

Little Eagle Creek Drain, Alva Osborn Arm, Atwater

Station 85+53 to Station 97+93

On this 27th day of September, 2021, the Hamilton County Drainage Board has held a hearing on the Maintenance Report and Schedule of Assessments of the Little Eagle Creek Drain, Alva Osborn Arm, Atwater (Station 85+53 to Station 97+93).

Evidence has been heard. Objections were presented and considered. The Board then adopted an order of action. The Board now finds that the costs of continued maintenance to the portion of the above drain exceed the benefits to the real estate benefited by the portion of the drain to be abandoned and issues this order vacating the above section of the Little Eagle Creek Drain, Alva Osborn Arm, Atwater (Station 85+53 to Station 97+93).

HAMILTON COUNTY DRAINAGE BOARD



President



Member



Member

Attest: 

STATE OF INDIANA)
) ss:
COUNTY OF HAMILTON)

BEFORE THE HAMILTON COUNTY
DRAINAGE BOARD
NOBLESVILLE, INDIANA

IN THE MATTER OF THE
RECONSTRUCTION OF THE
Little Eagle Creek Drain, Alva Osborn Arm, Atwater

FINDINGS AND ORDER FOR RECONSTRUCTION

The matter of the proposed Reconstruction of the **Little Eagle Creek Drain, Alva Osborn Arm, Atwater** came before the Hamilton County Drainage Board for hearing **on September 27, 2021**, on the Reconstruction Report consisting of the report and the Schedule of Damages and Assessments. The Board also received and considered the written objection of an owner of certain lands affected by the proposed Reconstruction, said owner being:

Evidence was heard on the Reconstruction Report and on the aforementioned objections.

The Board, having considered the evidence and objections, and, upon motion duly made, seconded and unanimously carried, did find and determine that the costs, damages and expenses of the proposed Reconstruction will be less than the benefits accruing to the owners of all land benefited by the Reconstruction.

The Board having considered the evidence and objections, upon motion duly made, seconded and unanimously carried, did adopt the Schedule of Assessments as proposed, subject to amendment after inspection of the subject drain as it relates to the lands of any owners which may have been erroneously included or omitted from the Schedule of Assessments.

The Board further finds that it has jurisdiction of these proceedings and that all required notices have been duly given or published as required by law.

Wherefore, it is ORDERED, that the proposed Reconstruction of the **Little Eagle Creek Drain, Alva Osborn Arm, Atwater** be and is hereby declared established.

Thereafter, the Board made inspection for the purpose of determining whether or not the lands of any owners had been erroneously included or excluded from the Schedule of Assessments. The Board finds on the basis of the reports and findings at this hearing as follows:

HAMILTON COUNTY DRAINAGE BOARD

PRESIDENT

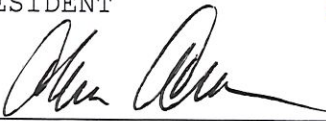
Member

Member

ATTEST:

Executive Secretary

Olthof Homes
 Project: Atwater Section 1
 HWC Project No. 2019-157
 Date: 10/16/2020

FILED

OCT 20 2020



HWC
 ENGINEERING

OFFICE OF HAMILTON COUNTY SURVEYOR
PERFORMANCE BOND - ENGINEERS ESTIMATE

	ITEM NAME:	UNIT	QUANTITY	UNIT COST	AMOUNT
STORM SEWER					
	42" RCP	LF	19	\$ 70.00	\$ 1,330.00
	48" RCP	LF	145	\$ 75.00	\$ 10,875.00
	60" RCP	LF	357	\$ 80.00	\$ 28,560.00
	RENO MATTRESS	CY	590	\$ 300.00	\$ 177,000.00
	MANHOLE, LARGE	EA	5	\$ 4,000.00	\$ 20,000.00
	STANDARD INLET	EA	5	\$ 2,000.00	\$ 10,000.00
	DOUBLE INLET	EA	1	\$ 4,000.00	\$ 4,000.00
	6'X5' BOX CULVERT	LF	94	\$ 1,100.00	\$ 103,400.00
	8'X6' BOX CULVERT	LF	95	\$ 1,400.00	\$ 133,000.00
	REMOVE EXISTING 66"X84" ELLIPTICAL CMP	LF	36	\$ 27.00	\$ 972.00
STORM SEWER SUBTOTAL:					\$ 489,137.00
STORM SEWER PERFORMANCE BOND (120%):					\$ 586,964.40
	ITEM NAME:	UNIT	QUANTITY	UNIT COST	AMOUNT
EROSION CONTROL					
	PERIMETER SILT FENCE	LF	13709	\$ 1.25	\$ 17,136.25
	TEMPORARY SEEDING W/MULCH	SY	8250	\$ 0.25	\$ 2,062.61
	PERMANENT SEEDING W/MULCH	SY	30603	\$ 0.50	\$ 15,301.28
	PERMANENT SEEDING W/BLANKET	SY	22529	\$ 1.25	\$ 28,160.69
	CURB INLET PROTECTION	EA	0	\$ 150.00	\$ -
	YARD INLET PROTECTION	EA	6	\$ 75.00	\$ 450.00
	CONSTRUCTION ENTRANCE	SY	696	\$ 10.00	\$ 6,963.33
	CONCRETE WASHOUT	LS	1	\$ 500.00	\$ 500.00
STORM SEWER SUBTOTAL:					\$ 70,574.16
STORM SEWER PERFORMANCE BOND (120%):					\$ 84,689.00

This Engineer's Estimate is an opinion of probable construction cost made on the basis of Engineer's experience and represent Engineer's judgement as a qualified professional generally familiar with the industry. However, since Engineer has no control over the cost of materials, equipment, labor or market conditions, Engineer cannot guarantee that actual construction cost will not vary from this Engineer's Estimate.

Hope A. Martin

Hope Martin, P.E.
 HWC Engineering



SUBDIVISION BOND

Bond No.: LICX1196190

Principal Amount: \$586,964.40

KNOW ALL MEN BY THESE PRESENTS, that we

Atwater Development, LLC
8051 Wicker Ave., Ste. A, St. John, IN 46373

as Principal, and

Lexon Insurance Company
12890 Lebanon Road, Mt. Juliet, TN 37122 a TX

Corporation, as Surety, are held and firmly bound unto

Hamilton County Drainage Board,
1 Hamilton County Square, Suite 188 Noblesville, IN 46060

as Obligee, in the penal sum of

Five Hundred Eighty Six Thousand Nine Hundred Sixty Four Dollars and 40/100

(Dollars) (\$ 586,964.40), lawful money of the United States of America, for the payment of which well and truly to be made, we bind ourselves, our heirs, executors, administrators, successors and assigns, jointly and severally, firmly by these presents.

WHEREAS, Atwater Development, LLC has agreed to construct in Atwater - Section 1 Subdivision, in Noblesville, IN the following improvements:

Storm Sewer

NOW, THEREFORE, THE CONDITION OF THIS OBLIGATION IS SUCH, that if the said Principal shall construct, or have constructed, the improvements herein described, and shall save the Obligee harmless from any loss, cost or damage by reason of its failure to complete said work, then this obligation shall be null and void, otherwise to remain in full force and effect, and the Surety, upon receipt of a resolution of the Obligee indicating that the improvements have not been installed or completed, will complete the improvements or pay to the Obligee such amount up to the Principal amount of this bond which will allow the Obligee to complete the improvements.

Upon approval by the Obligee, this instrument may be proportionately reduced as the public improvements are completed.

Signed, sealed and dated, this 27th day of October, 2020

Atwater Development, LLC
Principal

By: [Signature]

Lexon Insurance Company
Surety

By: [Signature]
James L. Moore Attorney-in-Fact





POWER OF ATTORNEY

KNOW ALL BY THESE PRESENTS, that Endurance Assurance Corporation, a Delaware corporation, Endurance American Insurance Company, a Delaware corporation, Lexion Insurance Company, a Texas corporation, and/or Bond Safeguard Insurance Company, a South Dakota corporation, each, a "Company" and collectively, "Sompo International," do hereby constitute and appoint: **James I. Moore**

as true and lawful Attorney(s)-in-Fact to make, execute, seal, and deliver for, and on its behalf as surety or co-surety; bonds and undertakings given for any and all purposes, also to execute and deliver on its behalf as aforesaid renewals, extensions, agreements, waivers, consents or stipulations relating to such bonds or undertakings provided, however, that no single bond or undertaking so made, executed and delivered shall obligate the Company for any portion of the penal sum thereof in excess of the sum of Five Million Dollars (\$5,000,000.00).

Surety Bond No.: LICX1196190
Principal: Atwater Development, LLC
Obligee: Hamilton County Drainage Board

Such bonds and undertakings for said purposes, when duly executed by said attorney(s)-in-fact, shall be binding upon the Company as fully and to the same extent as if signed by the President of the Company under its corporate seal attested by its Corporate Secretary.

This appointment is made under and by authority of certain resolutions adopted by the sole shareholder of each Company by unanimous written consent effective the 15th day of June, 2019, a copy of which appears below under the heading entitled "Certificate".

This Power of Attorney is signed and sealed by facsimile under and by authority of the following resolution adopted by the sole shareholder of each Company by unanimous written consent effective the 15th day of June, 2019 and said resolution has not since been revoked, amended or repealed:

RESOLVED, that the signature of an individual named above and the seal of the Company may be affixed to any such power of attorney or any certificate relating thereto by facsimile, and any such power of attorney or certificate bearing such facsimile signature or seal shall be valid and binding upon the Company in the future with respect to any bond or undertaking to which it is attached.

IN WITNESS WHEREOF, each Company has caused this instrument to be signed by the following officers, and its corporate seal to be affixed this 15th day of June, 2019.

Endurance Assurance Corporation
By: *Richard M. Appel*
Richard Appel; SVP & Senior Counsel



Endurance American Insurance Company
By: *Richard M. Appel*
Richard Appel; SVP & Senior Counsel



Lexion Insurance Company
By: *Richard M. Appel*
Richard Appel; SVP & Senior Counsel



Bond Safeguard Insurance Company
By: *Richard M. Appel*
Richard Appel; SVP & Senior Counsel



ACKNOWLEDGEMENT

On this 15th day of June, 2019, before me, personally came the above signatories known to me, who being duly sworn, did depose and say that he/she is the officer of each of the Companies; and that he executed said instrument on behalf of each Company by authority of his office under the by-laws of each Company.

By: *Amy Taylor*
Amy Taylor, Notary Public - My Commission Expires 5/9/23



CERTIFICATE

I, the undersigned Officer of each Company, DO HEREBY CERTIFY that:

1. That the original power of attorney of which the foregoing is a copy was duly executed on behalf of each Company and has not since been revoked, amended or modified; that the undersigned has compared the foregoing copy thereof with the original power of attorney, and that the same is a true and correct copy of the original power of attorney and of the whole thereof;
2. The following are resolutions which were adopted by the sole shareholder of each Company by unanimous written consent effective June 15, 2019 and said resolutions have not since been revoked, amended or modified:

"RESOLVED, that each of the individuals named below is authorized to make, execute, seal and deliver for and on behalf of the Company any and all bonds, undertakings or obligations in surety or co-surety with others: RICHARD M. APPEL, BRIAN J. BEGGS, CHRISTOPHER DONELAN, SHARON L. SIMS, CHRISTOPHER L. SPARRO, MARIANNE L. WILBERT

; and be it further

RESOLVED, that each of the individuals named above is authorized to appoint attorneys-in-fact for the purpose of making, executing, sealing and delivering bonds, undertakings or obligations in surety or co-surety for and on behalf of the Company."

3. The undersigned further certifies that the above resolutions are true and correct copies of the resolutions as so recorded and of the whole thereof.

IN WITNESS WHEREOF, I have hereunto set my hand and affixed the corporate seal this 27th day of October, 2020

By: *Daniel S. Lurie*
Daniel S. Lurie, Secretary

NOTICE: U. S. TREASURY DEPARTMENT'S OFFICE OF FOREIGN ASSETS CONTROL (OFAC)

No coverage is provided by this Notice nor can it be construed to replace any provisions of any surety bond or other surety coverage provided. This Notice provides information concerning possible impact on your surety coverage due to directives issued by OFAC. Please read this Notice carefully.

The Office of Foreign Assets Control (OFAC) administers and enforces sanctions policy, based on Presidential declarations of "national emergency". OFAC has identified and listed numerous foreign agents, front organizations, terrorists, terrorist organizations, and narcotics traffickers as "Specially Designated Nationals and Blocked Persons". This list can be located on the United States Treasury's website - <https://www.treasury.gov/resource-center/sanctions/SDN-List>.

In accordance with OFAC regulations, if it is determined that you or any other person or entity claiming the benefits of any coverage has violated U.S. sanctions law or is a Specially Designated National and Blocked Person, as identified by OFAC, any coverage will be considered a blocked or frozen contract and all provisions of any coverage provided are immediately subject to OFAC. When a surety bond or other form of surety coverage is considered to be such a blocked or frozen contract, no payments nor premium refunds may be made without authorization from OFAC. Other limitations on the premiums and payments may also apply.

Any reproductions are void.

Surety Claims Submission: LexionClaimAdministration@sompo-intl.com

Telephone: 615-553-9500 Mailing Address: Sompo International; 12890 Lebanon Road; Mount Juliet, TN 37122-2870

HC DID-2000-0001

RIDER

To be attached to and form a part of Bond No. LICX1196190

Effective: October 27, 2020

Bond Amount: \$586,964.40

Executed by: Atwater Development, LLC as Principal

and by: Lexon Insurance Company as Surety

in favor of: Hamilton County Drainage Board as Obligee

In consideration of the mutual agreements herein contained, at the request of the Principal, the Surety hereby changes the Obligee name and address to:

Hamilton County Commissioners
1 Hamilton County Square, Noblesville, IN 46060

Nothing herein contained shall vary, alter or extend any provision or condition of this bond except as herein expressly stated.

This rider is effective: October 27, 2020

Signed and Sealed: November 18, 2020

Atwater Development, LLC

Principal:

By: [Signature] Principal

Lexon Insurance Company

Surety:

By: [Signature]
James I. Moore, Attorney-in-Fact





KNOW ALL BY THESE PRESENTS, that Endurance Assurance Corporation, a Delaware corporation, Endurance American Insurance Company, a Delaware corporation, Lexon Insurance Company, a Texas corporation, and/or Bond Safeguard Insurance Company, a South Dakota corporation, each, a "Company" and collectively, "Sompo International," do hereby constitute and appoint: James I. Moore, Stephen T. Kazmor, Dawn L. Morgan, Kelly A. Gardner, Jennifer J. McComb, Melissa Schmidt, Tarlese M. Pisciotto, Diane Rubright, Amy Wickett, Martin Moss as true and lawful Attorney(s)-in-Fact to make, execute, seal, and deliver for, and on its behalf as surety or co-surety; bonds and undertakings given for any and all purposes, also to execute and deliver on its behalf as aforesaid renewals, extensions, agreements, waivers, consents or stipulations relating to such bonds or undertakings provided, however, that no single bond or undertaking so made, executed and delivered shall obligate the Company for any portion of the penal sum thereof in excess of the sum of FIFTEEN MILLION Dollars (\$15,000,000.00).





Such bonds and undertakings for said purposes, when duly executed by said attorney(s)-in-fact, shall be binding upon the Company as fully and to the same extent as if signed by the President of the Company under its corporate seal attested by its Corporate Secretary.

This appointment is made under and by authority of certain resolutions adopted by the sole shareholder of each Company by unanimous written consent effective the 15th day of June, 2019, a copy of which appears below under the heading entitled "Certificate".

This Power of Attorney is signed and sealed by facsimile under and by authority of the following resolution adopted by the sole shareholder of each Company by unanimous written consent effective the 15th day of June, 2019 and said resolution has not since been revoked, amended or repealed:

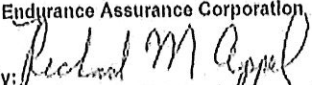
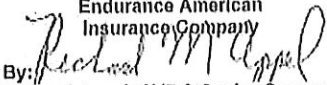
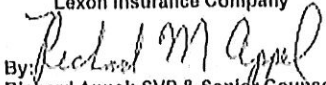
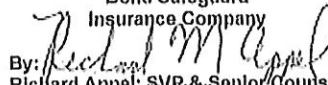
RESOLVED, that the signature of an individual named above and the seal of the Company may be affixed to any such power of attorney or any certificate relating thereto by facsimile, and any such power of attorney or certificate bearing such facsimile signature or seal shall be valid and binding upon the Company in the future with respect to any bond or undertaking to which it is attached.

IN WITNESS WHEREOF, each Company has caused this instrument to be signed by the following officers, and its corporate seal to be affixed this 15th day of June, 2019.

Endurance Assurance Corporation By:  Richard Appel; SVP & Senior Counsel	Endurance American Insurance Company By:  Richard Appel; SVP & Senior Counsel	Lexon Insurance Company By:  Richard Appel; SVP & Senior Counsel	Bond Safeguard Insurance Company By:  Richard Appel; SVP & Senior Counsel
			

ACKNOWLEDGEMENT

On this 15th day of June, 2019, before me, personally came the above signatories known to me, who being duly sworn, did depose and say that he/she is an officer of each of the Companies; and that he executed said instrument on behalf of each Company by authority of his office under the by-laws of each Company.

By: 
Amy Taylor, Notary Public - My Commission Expires 5/9/23

CERTIFICATE

I, the undersigned Officer of each Company, DO HEREBY CERTIFY that:

- That the original power of attorney of which the foregoing is a copy was duly executed on behalf of each Company and has not since been revoked, amended or modified; that the undersigned has compared the foregoing copy thereof with the original power of attorney, and that the same is a true and correct copy of the original power of attorney and of the whole thereof;
- The following are resolutions which were adopted by the sole shareholder of each Company by unanimous written consent effective June 15, 2019 and said resolutions have not since been revoked, amended or modified:

*RESOLVED, that each of the individuals named below is authorized to make, execute, seal and deliver for and on behalf of the Company any and all bonds, undertakings or obligations in surety or co-surety with others: RICHARD M. APPEL, BRIAN J. BEGGS, CHRISTOPHER DONELAN, SHARON L. SIMS, CHRISTOPHER L. SPARRO, MARIANNE L. WILBERT

; and be it further

RESOLVED, that each of the individuals named above is authorized to appoint attorneys-in-fact for the purpose of making, executing, sealing and delivering bonds, undertakings or obligations in surety or co-surety for and on behalf of the Company."

- The undersigned further certifies that the above resolutions are true and correct copies of the resolutions as so recorded and of the whole thereof.

IN WITNESS WHEREOF, I have hereunto set my hand and affixed the corporate seal this 18th day of November, 2020.

By: 
Daniel S. Kurie, Secretary

NOTICE: U. S. TREASURY DEPARTMENT'S OFFICE OF FOREIGN ASSETS CONTROL (OFAC)

No coverage is provided by this Notice nor can it be construed to replace any provisions of any surety bond or other surety coverage provided. This Notice provides information concerning possible impact on your surety coverage due to directives issued by OFAC. Please read this Notice carefully.

The Office of Foreign Assets Control (OFAC) administers and enforces sanctions policy, based on Presidential declarations of "national emergency". OFAC has identified and listed numerous foreign agents, front organizations, terrorists, terrorist organizations, and narcotics traffickers as "Specially Designated Nationals and Blocked Persons". This list can be located on the United States Treasury's website - <https://www.treasury.gov/resource-center/sanctions/SDN-List>.

In accordance with OFAC regulations, if it is determined that you or any other person or entity claiming the benefits of any coverage has violated U.S. sanctions law or is a Specially Designated National and Blocked Person, as identified by OFAC, any coverage will be considered a blocked or frozen contract and all provisions of any coverage provided are immediately subject to OFAC. When a surety bond or other form of surety coverage is considered to be such a blocked or frozen contract, no payments nor premium refunds may be made without authorization from OFAC. Other limitations on the premiums and payments may also apply.

Any reproductions are void.

Surety Claims Submission: LexonClaimAdministration@sompo-intl.com

Telephone: 615-553-9500 Mailing Address: Sompo International; 12890 Lohanon Road; Mount Juliet, TN 37122-2070

SUBDIVISION BOND

Bond No.: LICX1196191

Principal Amount: \$84,689.00

KNOW ALL MEN BY THESE PRESENTS, that we

Atwater Development, LLC
8051 Wicker Ave., Ste. A, St. John, IN 46373

as Principal, and

Lexon Insurance Company
12890 Lebanon Road, Mt. Juliet, TN 37122 a TX

Corporation, as Surety, are held and firmly bound unto
Hamilton County Drainage Board,

1 Hamilton County Square, Suite 188 Noblesville, IN 46060

as Obligee, in the penal sum of

Eighty Four Thousand Six Hundred Eighty Nine Dollars and 00/100

(Dollars) (\$ 84,689.00), lawful money of the

United States of America, for the payment of which well and truly to be made, we bind ourselves, our heirs, executors, administrators, successors and assigns, jointly and severally, firmly by these presents.

WHEREAS, Atwater Development, LLC has agreed to construct in
Atwater - Section 1 Subdivision, in Noblesville, IN the following
improvements:

Erosion Control

NOW, THEREFORE, THE CONDITION OF THIS OBLIGATION IS SUCH, that if the said Principal shall construct, or have constructed, the improvements herein described, and shall save the Obligee harmless from any loss, cost or damage by reason of its failure to complete said work, then this obligation shall be null and void, otherwise to remain in full force and effect, and the Surety, upon receipt of a resolution of the Obligee indicating that the improvements have not been installed or completed, will complete the improvements or pay to the Obligee such amount up to the Principal amount of this bond which will allow the Obligee to complete the improvements.

Upon approval by the Obligee, this instrument may be proportionately reduced as the public improvements are completed.

Signed, sealed and dated, this 27th day of October, 2020

Atwater Development, LLC
Principal

By: [Signature]

Lexon Insurance Company
Surety

By: [Signature]
James I. Moore Attorney-in-Fact





POWER OF ATTORNEY

KNOW ALL BY THESE PRESENTS, that Endurance Assurance Corporation, a Delaware corporation, Endurance American Insurance Company, a Delaware corporation, Lexion Insurance Company, a Texas corporation, and/or Bond Safeguard Insurance Company, a South Dakota corporation, each, a "Company" and collectively, "Sompo International," do hereby constitute and appoint: **James I. Moore**

as true and lawful Attorney(s)-In-Fact to make, execute, seal, and deliver for, and on its behalf as surety or co-surety; bonds and undertakings given for any and all purposes, also to execute and deliver on its behalf as aforesaid renewals, extensions, agreements, waivers, consents or stipulations relating to such bonds or undertakings provided, however, that no single bond or undertaking so made, executed and delivered shall obligate the Company for any portion of the penal sum thereof in excess of the sum of Five Million Dollars (\$5,000,000.00).

Surety Bond No.: LICX1196191
Principal: Atwater Development, LLC
Obligee: Hamilton County Drainage Board

Such bonds and undertakings for said purposes, when duly executed by said attorney(s)-in-fact, shall be binding upon the Company as fully and to the same extent as if signed by the President of the Company under its corporate seal attested by its Corporate Secretary.

This appointment is made under and by authority of certain resolutions adopted by the sole shareholder of each Company by unanimous written consent effective the 15th day of June, 2019, a copy of which appears below under the heading entitled "Certificate".

This Power of Attorney is signed and sealed by facsimile under and by authority of the following resolution adopted by the sole shareholder of each Company by unanimous written consent effective the 15th day of June, 2019 and said resolution has not since been revoked, amended or repealed:

RESOLVED, that the signature of an individual named above and the seal of the Company may be affixed to any such power of attorney or any certificate relating thereto by facsimile, and any such power of attorney or certificate bearing such facsimile signature or seal shall be valid and binding upon the Company in the future with respect to any bond or undertaking to which it is attached.

IN WITNESS WHEREOF, each Company has caused this instrument to be signed by the following officers, and its corporate seal to be affixed this 15th day of June, 2019.

Endurance Assurance Corporation
By: *Richard Appel*
Richard Appel, SVP & Senior Counsel



Endurance American Insurance Company
By: *Richard Appel*
Richard Appel, SVP & Senior Counsel



Lexion Insurance Company
By: *Richard Appel*
Richard Appel, SVP & Senior Counsel



Bond Safeguard Insurance Company
By: *Richard Appel*
Richard Appel, SVP & Senior Counsel



ACKNOWLEDGEMENT

On this 15th day of June, 2019, before me, personally came the above signatories known to me, who being duly sworn, did depose and say that he/she is an officer of each of the Companies; and that he executed said instrument on behalf of each Company by authority of his office under the by-laws of each Company.

By: *Amy Taylor*
Amy Taylor, Notary Public - My Commission Expires 5/9/23



CERTIFICATE

I, the undersigned Officer of each Company, DO HEREBY CERTIFY that:

1. That the original power of attorney of which the foregoing is a copy was duly executed on behalf of each Company and has not since been revoked, amended or modified; that the undersigned has compared the foregoing copy thereof with the original power of attorney, and that the same is a true and correct copy of the original power of attorney and of the whole thereof;
2. The following are resolutions which were adopted by the sole shareholder of each Company by unanimous written consent effective June 15, 2019 and said resolutions have not since been revoked; amended or modified:

"RESOLVED, that each of the individuals named below is authorized to make, execute, seal and deliver for and on behalf of the Company any and all bonds, undertakings or obligations in surety or co-surety with others: RICHARD M. APPEL, BRIAN J. BEGGS, CHRISTOPHER DONELAN, SHARON L. SIMS, CHRISTOPHER L. SPARRO, MARIANNE L. WILBERT ; and be it further

RESOLVED, that each of the individuals named above is authorized to appoint attorneys-in-fact for the purpose of making, executing, sealing and delivering bonds, undertakings or obligations in surety or co-surety for and on behalf of the Company."

3. The undersigned further certifies that the above resolutions are true and correct copies of the resolutions as so recorded and of the whole thereof.

IN WITNESS WHEREOF, I have hereunto set my hand and affixed the corporate seal this 27th day of October, 2020

By: *Daniel S. Lurie*
Daniel S. Lurie, Secretary

NOTICE: U. S. TREASURY DEPARTMENT'S OFFICE OF FOREIGN ASSETS CONTROL (OFAC)

No coverage is provided by this Notice nor can it be construed to replace any provisions of any surety bond or other surety coverage provided. This Notice provides information concerning possible impact on your surety coverage due to directives issued by OFAC. Please read this Notice carefully.

The Office of Foreign Assets Control (OFAC) administers and enforces sanctions policy, based on Presidential declarations of "national emergency". OFAC has identified and listed numerous foreign agents, front organizations, terrorists, terrorist organizations, and narcotics traffickers as "Specially Designated Nationals and Blocked Persons". This list can be located on the United States Treasury's website - <https://www.treasury.gov/resource-center/sanctions/SDN-List>.

In accordance with OFAC regulations, if it is determined that you or any other person or entity claiming the benefits of any coverage has violated U.S. sanctions law or is a Specially Designated National and Blocked Person, as identified by OFAC, any coverage will be considered a blocked or frozen contract and all provisions of any coverage provided are immediately subject to OFAC. When a surety bond or other form of surety coverage is considered to be such a blocked or frozen contract, no payments nor premium refunds may be made without authorization from OFAC. Other limitations on the premiums and payments may also apply.

Any reproductions are void.

Surety Claims Submission: LexionClaimAdministration@sompo-intl.com

Telephone: 615-553-9500 Mailing Address: Sompo International; 12890 Lebanon Road; Mount Juliet, TN 37122-2870

RIDER

To be attached to and form a part of Bond No. LICX1196191

Effective: October 27, 2020

Bond Amount: \$84,689.00

Executed by: Atwater Development, LLC as Principal

and by: Lexon Insurance Company as Surety

in favor of: Hamilton County Drainage Board as Obligee

In consideration of the mutual agreements herein contained, at the request of the Principal, the Surety hereby changes the Obligee name and address to:

Hamilton County Commissioners
1 Hamilton County Square, Noblesville, IN 46060

Nothing herein contained shall vary, alter or extend any provision or condition of this bond except as herein expressly stated.

This rider is effective: October 27, 2020

Signed and Sealed: November 18, 2020

Atwater Development, LLC

Principal:

By: [Signature] _____
Principal

Lexon Insurance Company

Surety:

By: [Signature]
James I. Moore, Attorney-in-Fact





KNOW ALL BY THESE PRESENTS, that Endurance Assurance Corporation, a Delaware corporation, Endurance American Insurance Company, a Delaware corporation, Lexon Insurance Company, a Texas corporation, and/or Bond Safeguard Insurance Company, a South Dakota corporation, each, a "Company" and collectively, "Sompo International," do hereby constitute and appoint: James I. Moore, Stephen T. Kazmer, Dawn L. Morgan, Kelly A. Gardner, Jennifer J. McComb, Melissa Schmidt, Tarlese M. Piscolto, Diane Rubright, Amy Wickett, Martin Moss as true and lawful Attorney(s)-In-Fact to make, execute, seal, and deliver for, and on its behalf as surety or co-surety; bonds and undertakings given for any and all purposes, also to execute and deliver on its behalf as aforesaid renewals, extensions, agreements, waivers, consents or stipulations relating to such bonds or undertakings provided, however, that no single bond or undertaking so made, executed and delivered shall obligate the Company for any portion of the penal sum thereof in excess of the sum of FIFTEEN MILLION Dollars (\$15,000,000.00).

Such bonds and undertakings for said purposes, when duly executed by said attorney(s)-in-fact, shall be binding upon the Company as fully and to the same extent as if signed by the President of the Company under its corporate seal attested by its Corporate Secretary.

This appointment is made under and by authority of certain resolutions adopted by the sole shareholder of each Company by unanimous written consent effective the 15th day of June, 2019, a copy of which appears below under the heading entitled "Certificate".

This Power of Attorney is signed and sealed by facsimile under and by authority of the following resolution adopted by the sole shareholder of each Company by unanimous written consent effective the 15th day of June, 2019 and said resolution has not since been revoked, amended or repealed:

RESOLVED, that the signature of an individual named above and the seal of the Company may be affixed to any such power of attorney or any certificate relating thereto by facsimile, and any such power of attorney or certificate bearing such facsimile signature or seal shall be valid and binding upon the Company in the future with respect to any bond or undertaking to which it is attached.

IN WITNESS WHEREOF, each Company has caused this instrument to be signed by the following officers, and its corporate seal to be affixed this 15th day of June, 2019.

Endurance Assurance Corporation
By: Richard Appel, SVP & Senior Counsel

Endurance American Insurance Company
By: Richard Appel, SVP & Senior Counsel

Lexon Insurance Company
By: Richard Appel, SVP & Senior Counsel

Bond Safeguard Insurance Company
By: Richard Appel, SVP & Senior Counsel



ACKNOWLEDGEMENT

On this 15th day of June, 2019, before me, personally came the above signatories known to me, who being duly sworn, did depose and say that he/she is an officer of each of the Companies; and that he executed said instrument on behalf of each Company by authority of his office under the by-laws of each Company.

By: Amy Taylor, Notary Public - My Commission Expires 5/9/23

CERTIFICATE

I, the undersigned Officer of each Company, DO HEREBY CERTIFY that:

- 1. That the original power of attorney of which the foregoing is a copy was duly executed on behalf of each Company and has not since been revoked, amended or modified; that the undersigned has compared the foregoing copy thereof with the original power of attorney, and that the same is a true and correct copy of the original power of attorney and of the whole thereof;
2. The following are resolutions which were adopted by the sole shareholder of each Company by unanimous written consent effective June 15, 2019 and said resolutions have not since been revoked, amended or modified:

*RESOLVED, that each of the individuals named below is authorized to make, execute, seal and deliver for and on behalf of the Company any and all bonds, undertakings or obligations in surety or co-surety with others: RICHARD M. APPEL, BRIAN J. BEGGS, CHRISTOPHER DONELAN, SHARON L. SIMS, CHRISTOPHER L. SPARRO, MARIANNE L. WILBERT

; and be it further

RESOLVED, that each of the individuals named above is authorized to appoint attorneys-in-fact for the purpose of making, executing, sealing and delivering bonds, undertakings or obligations in surety or co-surety for and on behalf of the Company."

- 3. The undersigned further certifies that the above resolutions are true and correct copies of the resolutions as so recorded and of the whole thereof.

IN WITNESS WHEREOF, I have hereunto set my hand and affixed the corporate seal this 18th day of November, 2020.

By: Daniel S. Lurie, Secretary

NOTICE: U. S. TREASURY DEPARTMENT'S OFFICE OF FOREIGN ASSETS CONTROL (OFAC)

No coverage is provided by this Notice nor can it be construed to replace any provisions of any surety bond or other surety coverage provided. This Notice provides information concerning possible impact on your surety coverage due to directives issued by OFAC. Please read this Notice carefully.

The Office of Foreign Assets Control (OFAC) administers and enforces sanctions policy, based on Presidential declarations of "national emergency". OFAC has identified and listed numerous foreign agents, front organizations, terrorists, terrorist organizations, and narcotics traffickers as "Specially Designated Nationals and Blocked Persons". This list can be located on the United States Treasury's website - https://www.treasury.gov/resource-center/sanctions/SDN-List.

In accordance with OFAC regulations, if it is determined that you or any other person or entity claiming the benefits of any coverage has violated U.S. sanctions law or is a Specially Designated National and Blocked Person, as identified by OFAC, any coverage will be considered a blocked or frozen contract and all provisions of any coverage provided are immediately subject to OFAC. When a surety bond or other form of surety coverage is considered to be such a blocked or frozen contract, no payments nor premium refunds may be made without authorization from OFAC. Other limitations on the premiums and payments may also apply.

Any reproductions are void.

Surety Claims Submission: LexonClaimAdministration@sompo-intl.com

Telephone: 615-553-9500 Mailing Address: Sompo International; 12890 Lebanon Road; Mount Juliet, TN 37122-2870

BEFORE THE HAMILTON COUNTY DRAINAGE BOARD
IN THE MATTER OF

***Little Eagle Creek Drain,
Alva Osborn Arm, Atwater***

NOTICE

To Whom It May Concern and: _____

Notice is hereby given of the hearing of the Hamilton County Drainage Board concerning the reconstruction of the **Little Eagle Creek Drain, Alva Osborn Arm, Atwater** on **September 27, 2021** at **9:00 A.M.** in Commissioners Court, Hamilton County Judicial Center, One Hamilton County Square, Noblesville, Indiana. Construction and maintenance reports of the Surveyor and the Schedule of Assessments proposed by the Drainage Board have been filed and are available for public inspection in the office of the Hamilton County Surveyor.

Hamilton County Drainage Board

Attest: Lynette Mosbaugh

ONE TIME ONLY

STATE OF INDIANA)
) SS BEFORE THE HAMILTON
)
COUNTY OF HAMILTON) DRAINAGE BOARD

IN THE MATTER OF **Little Eagle Creek Drain, Alva Osborn Arm,
Atwater**

NOTICE

Notice is hereby given that the Hamilton County Drainage Board at its regular meeting **September 27, 2021** adopted the reconstruction report of the Surveyor and the Amended Schedule of damages and assessments including annual assessment for periodic maintenance, finding that the costs, damages and expense of the proposed improvement would be less than the benefits which will result to the owner of lands benefited thereby.

The Board issued an order declaring the proposed improvement established. Such findings and order were marked filed and are available for inspection in the Office of the Hamilton County Surveyor.

If judicial review of the findings and order of the Board is not requested pursuant to Article VIII of the 1965 Indiana Drainage Code as amended within twenty (20) days from the date of publication of this notice, the findings and order shall become conclusive.

HAMILTON COUNTY DRAINAGE BOARD

BY: Steven C. Dillinger
PRESIDENT

ATTEST: Lynette Mosbaugh
SECRETARY

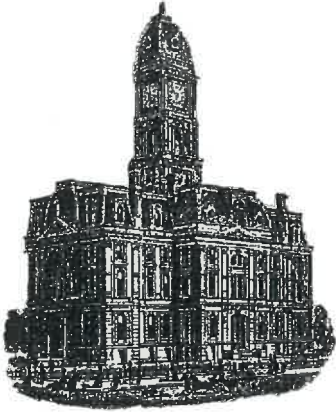

Kenton C. Ward, CFM
Surveyor of Hamilton County
Phone (317) 776-8495
Fax (317) 776-9628

Suite 188
One Hamilton County Square
Noblesville, Indiana 46060-2230

To: Hamilton County Drainage Board

August 10, 2022

Re: Little Eagle Creek: Alva Osborn Drain – Atwater Relocation

Attached are as built, and other information for Atwater Section 1. An inspection of the drainage facilities for this section has been made and the facilities were found to be complete and acceptable.

During construction, changes were made to the drain, which will alter the plans submitted with my report for this drain-dated August 6, 2021. The report was approved by the Board at the hearing held September 27, 2021. (See Drainage Board Minutes Book 20, Pages 163-165) The changes are as follows: the 60" RCP was shortened from 26 feet to 22 feet. The open ditch was shortened from 1361 feet to 1286 feet. The length of the drain due to the changes described above is now **1497feet**. The project removed the original 20" tile from Station 85+53 to Station 97+93. Also removed was the 2002 SCS outlet Reconstruction Arm. It consisted of 80' of 24" plastic tile.

The non-enforcement was approved by the Board at its meeting on September 27, 2021 and recorded under instrument #2022015009.

The following sureties were guaranteed by Lexon Insurance Co. and released by the Board on its August 22, 2022, meeting.

Bond-LC: LICX1196190
Amount: \$586,964.40
For: Storm Sewers & SSD
Issue Date: October 27, 2020

I recommend the Board approve the drain's construction as complete and acceptable.

Sincerely,

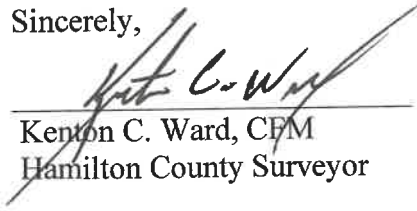

Kenton C. Ward, CFM
Hamilton County Surveyor

Suzie L. Mills

From: Shawn Donaldson <sdonaldson@hwcengineering.com>
Sent: Friday, April 1, 2022 12:01 PM
To: Tim Walsh; Suzie L. Mills; Luther M. Cline
Cc: Hope Martin; kkibler@olthofhomes.com; Ed Recktenwall;
brobinson@stoepfelwerth.com; Jon Crawford
Subject: RE: Atwater Section 1 - As-built Submittal

CAUTION: This email originated from outside of the organization. Do not click links or open attachments unless you recognize the sender and know the content is safe.

Tim,

We did get the remaining field work completed this week but I haven't been able to process it yet. I should be able to send over on Monday.

From: Tim Walsh <twalsh@platinum-properties.com>
Sent: Friday, April 1, 2022 11:57 AM
To: Shawn Donaldson <sdonaldson@hwcengineering.com>; Suzie L. Mills <Suzie.Mills@hamiltoncounty.in.gov>; Luther M. Cline <Luther.Cline@hamiltoncounty.in.gov>
Cc: Hope Martin <hmartin@hwcengineering.com>; kkibler@olthofhomes.com; Ed Recktenwall <erecktenwall@olthofhomes.com>; brobinson@stoepfelwerth.com; Jon Crawford <jcrawford@hwcengineering.com>
Subject: RE: Atwater Section 1 - As-built Submittal

Shawn, Have you been able to submit this to the county yet?

Thanks,

Tim Walsh
Sr. Project Manager
Platinum Properties Mgmt Co, LLC
twalsh@platinum-properties.com
317.258.8577

From: Shawn Donaldson <sdonaldson@hwcengineering.com>
Sent: Monday, March 7, 2022 3:54 PM
To: Suzie L. Mills <Suzie.Mills@hamiltoncounty.in.gov>; Luther M. Cline <Luther.Cline@hamiltoncounty.in.gov>
Cc: Hope Martin <hmartin@hwcengineering.com>; kkibler@olthofhomes.com; Ed Recktenwall <erecktenwall@olthofhomes.com>; Tim Walsh <twalsh@platinum-properties.com>; brobinson@stoepfelwerth.com;
Jon Crawford <jcrawford@hwcengineering.com>
Subject: RE: Atwater Section 1 - As-built Submittal

Suzie,

We collected structure information only. Our field manager has been made aware and we will collect that data and resubmit. Our apologies for any confusion.

From: Suzie L. Mills <Suzie.Mills@hamiltoncounty.in.gov>

Sent: Monday, March 7, 2022 1:30 PM

To: Shawn Donaldson <sdonaldson@hwcengineering.com>; Luther M. Cline <Luther.Cline@hamiltoncounty.in.gov>

Cc: Hope Martin <hmartin@hwcengineering.com>; kkibler@olthofhomes.com; Ed Recktenwall <erecktenwall@olthofhomes.com>; Tim Walsh <twalsh@platinum-properties.com>; brobinson@stoepfelwerth.com

Subject: RE: Atwater Section 1 - As-built Submittal

Hi Shawn,

I am looking through the submittal posted on Friday. One major concern I have is the open ditch information provided. There is no indication by the lack of markings that the open ditch was surveyed for as-built elevations. Was the open ditch surveyed?

Thanks,

Suzie

From: Shawn Donaldson <sdonaldson@hwcengineering.com>

Sent: Friday, March 4, 2022 10:40 AM

To: Suzie L. Mills <Suzie.Mills@hamiltoncounty.in.gov>; Luther M. Cline <Luther.Cline@hamiltoncounty.in.gov>

Cc: Hope Martin <hmartin@hwcengineering.com>; kkibler@olthofhomes.com; Ed Recktenwall <erecktenwall@olthofhomes.com>; Tim Walsh <twalsh@platinum-properties.com>; brobinson@stoepfelwerth.com

Subject: Atwater Section 1 - As-built Submittal

CAUTION: This email originated from outside of the organization. Do not click links or open attachments unless you recognize the sender and know the content is safe.

Suzie,

Below is a link to the as-builts for Atwater Section 1. Please review at your earliest convenience and let us know if you need any additional information. Thank you.

 [Atwater Section 1 As-built Deliverables](#)

Respectfully submitted,

Shawn Donaldson
Project Surveyor

135 N. Pennsylvania Street, Suite 2800
Indianapolis, IN 46204
(o) 317-981-1290
(c) 317-652-6617

www.hwcengineering.com



HWC
ENGINEERING



[Like us on Facebook](#)



Please consider the environment before printing this e-mail

The information contained in this communication is confidential, private, proprietary, or

otherwise privileged and is intended only for the use of the addressee. Unauthorized use, disclosure, distribution or copying is strictly prohibited and may be unlawful. If you have received this communication in error, please notify the sender immediately at 317-347-3663.

The information in this email may contain confidential information and is intended solely for the attention and use of the named addressee(s). It must not be disclosed to any person(s) without authorization. If you are not the intended recipient, or a person responsible for delivering it to the intended recipient, you are not authorized to, and must not disclose, copy, distribute, or retain this message or any part of it. If you have received this communication in error, please notify the sender immediately.

BENCHMARK INFORMATION:

ORIGINATING BENCHMARK:
HAMILTON COUNTY SURVEYOR'S OFFICE VERTICAL CONTROL BENCHMARK "LEE 12", SET IN TOP OF A CONCRETE POST, LOCATED AT THE NORTHWEST CORNER OF THE INTERSECTION OF CASEY ROAD AND 186TH STREET IN WESTFIELD.

PUBLISHED ELEVATION = 910.25 FEET (NAVD 88)
[NORTHING: 175,335; EASTING: 737,077] (InGCS-HAMILTON ZONE)

TEMPORARY BENCHMARKS HAVE BEEN ESTABLISHED VIA DIFFERENTIAL LEVELING, REFERENCED TO THE NORTH AMERICAN VERTICAL DATUM OF 1988 (NAVD 88). HORIZONTAL COORDINATES ARE LISTED FOR REFERENCE PURPOSES, REFERENCED TO THE INDIANA GEOSPATIAL COORDINATE SYSTEM (InGCS) "HAMILTON" ZONE.

TBM #2
MAG SPIKE AND CAP 1 FOOT ABOVE GRADE ON THE NORTH SIDE OF POWER POLE "PSI 838 8 273", LOCATED ALONG THE NORTH SIDE OF WEST 193RD STREET APPROXIMATELY 480 FEET WEST OF THE INTERSECTION WITH CASEY ROAD.
ELEVATION = 921.05 (NAVD88)
[NORTHING: 179,278; EASTING: 736,590] (InGCS-HAMILTON ZONE)

TBM #3
RAILROAD SPIKE 1.5 FEET ABOVE GRADE ON THE NORTH SIDE OF POWER POLE "PSI 838 8 49", LOCATED ALONG THE SOUTH SIDE OF WEST 193RD STREET APPROXIMATELY 460 FEET WEST OF THE INTERSECTION WITH CASEY ROAD.
ELEVATION = 923.08 (NAVD88)
[NORTHING: 179,259; EASTING: 737,548] (InGCS-HAMILTON ZONE)

TBM #9
MAG SPIKE AND CAP 1 FOOT ABOVE GRADE ON THE NORTHEAST SIDE OF POWER POLE "PSI 838 8 336", LOCATED ALONG THE WEST SIDE OF SIX POINTS ROAD 1,540 FEET NORTH OF THE INTERSECTION WITH WEST 193RD ST. THE POWER POLE IS 77 FEET NORTH OF A LARGE CULVERT CROSSING UNDER SIX POINTS ROAD.
ELEVATION = 925.26 (NAVD88)
[NORTHING: 180,818; EASTING: 738,393] (InGCS-HAMILTON ZONE)

TBM #10
MAG SPIKE AND CAP 1 FOOT ABOVE GRADE IN POWER POLE "ENERGY 838 8326", LOCATED ALONG THE WEST SIDE OF SIX POINTS. THE POWER POLE IS APPROX. 940 FEET SOUTH OF THE DRIVEWAY FOR ADDRESS 20248 SIX POINTS ROAD.
ELEVATION = 931.22 (NAVD88)
[NORTHING: 182,848; EASTING: 738,385] (InGCS-HAMILTON ZONE)

LEGEND:

EXISTING		PROPOSED	
---	RIGHT-OF-WAY LINE	---	EASEMENT LINE
---	SETBACK LINE	---	CENTERLINE
---	SUBSURFACE DRAIN	---	SWALE / FLOWLINE
---	SANITARY SEWER	---	STORM SEWER
---	STORM CULVERT	---	WATER MAIN
---	SANITARY MANHOLE	---	STORM MANHOLE
---	STORM MANHOLE	---	STORM INLET
---	STORM END SECTION	---	FIRE HYDRANT
---	PROFILLED PIPELINE	---	RCP - REINFORCED CONCRETE PIPE
---	TC - TOP OF CASTING GRADE	---	

Pipe Table

UPSTREAM TO DOWNSTREAM	PIPE LENGTH (FT)	PIPE DIA. (IN)
102-101	229	60"
103-102	94	60"
104-103	202	60"
105-104	203	60"
106-105	282	60"
107-106	47	60"
110-104	66	21"

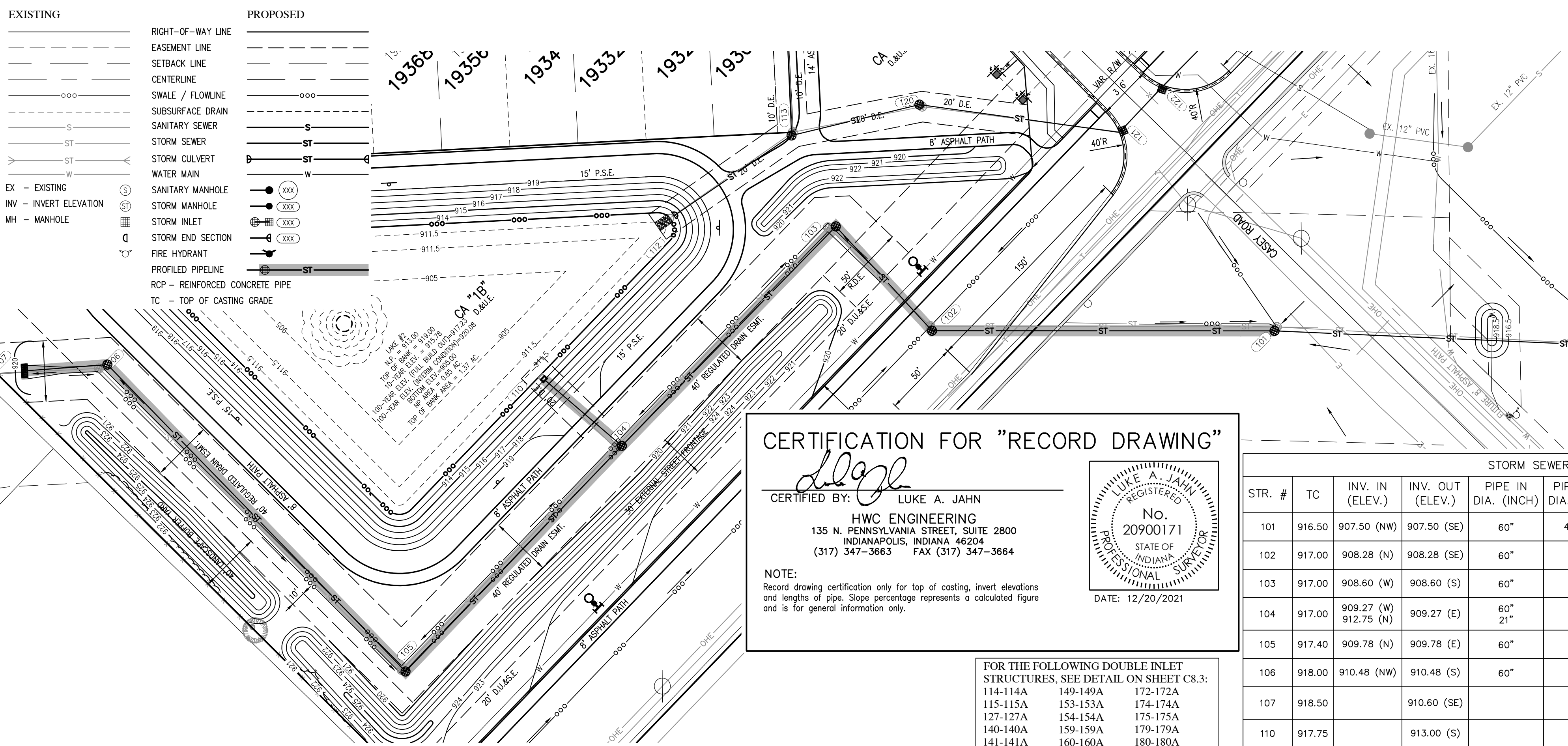

CERTIFICATION FOR "RECORD DRAWING"

CERTIFIED BY: *LUKE A. JAHN*

LUKE A. JAHN
REGISTERED PROFESSIONAL SURVEYOR
No. 20900171
STATE OF INDIANA

HWC ENGINEERING
135 N. PENNSYLVANIA STREET, SUITE 2800
INDIANAPOLIS, INDIANA 46204
(317) 347-3663 FAX (317) 347-3664

DATE: 12/20/2021

NOTE:
Record drawing certification only for top of casting, invert elevations and lengths of pipe. Slope percentage represents a calculated figure and is for general information only.

STORM SEWER STRUCTURE DATA TABLE

STR. #	TC	INV. IN (ELEV.)	INV. OUT (ELEV.)	PIPE IN DIA. (INCH)	PIPE OUT DIA. (INCH)	PIPE IN MATERIAL	PIPE OUT MATERIAL	STR. & CASTING TYPE
101	916.50	907.50 (NW)	907.50 (SE)	60"	48"x76"	RCP	RCP	MANHOLE TYPE N NEENAH R-4342
102	917.00	908.28 (N)	908.28 (SE)	60"	60"	RCP	RCP	MANHOLE TYPE L NEENAH R-4342
103	917.00	908.60 (W)	908.60 (S)	60"	60"	RCP	RCP	MANHOLE TYPE N NEENAH R-4342
104	917.00	909.27 (W) 912.75 (N)	909.27 (E)	60" 21"	60"	RCP RCP	RCP	MANHOLE TYPE L NEENAH R-4342
105	917.40	909.78 (N)	909.78 (E)	60"	60"	RCP	RCP	MANHOLE TYPE N NEENAH R-4342
106	918.00	910.48 (NW)	910.48 (S)	60"	60"	RCP	RCP	MANHOLE TYPE L NEENAH R-4342
107	918.50		910.60 (SE)		60"		RCP	3'x8" CONCRETE BOX STRUCTURE 4 (FOUR) NEENAH R-4857 TYPE A GRATES
110	917.75		913.00 (S)		21"		RCP	POND OUTLET CONTROL STRUCTURE

FOR THE FOLLOWING DOUBLE INLET STRUCTURES, SEE DETAIL ON SHEET C8.3:
114-114A 149-149A 172-172A
115-115A 153-153A 174-174A
127-127A 154-154A 175-175A
140-140A 159-159A 179-179A
141-141A 160-160A 180-180A
148-148A 171-171A

STORM PROFILE

VERTICAL SCALE: 1" = 5'
HORIZONTAL SCALE: 1" = 50'

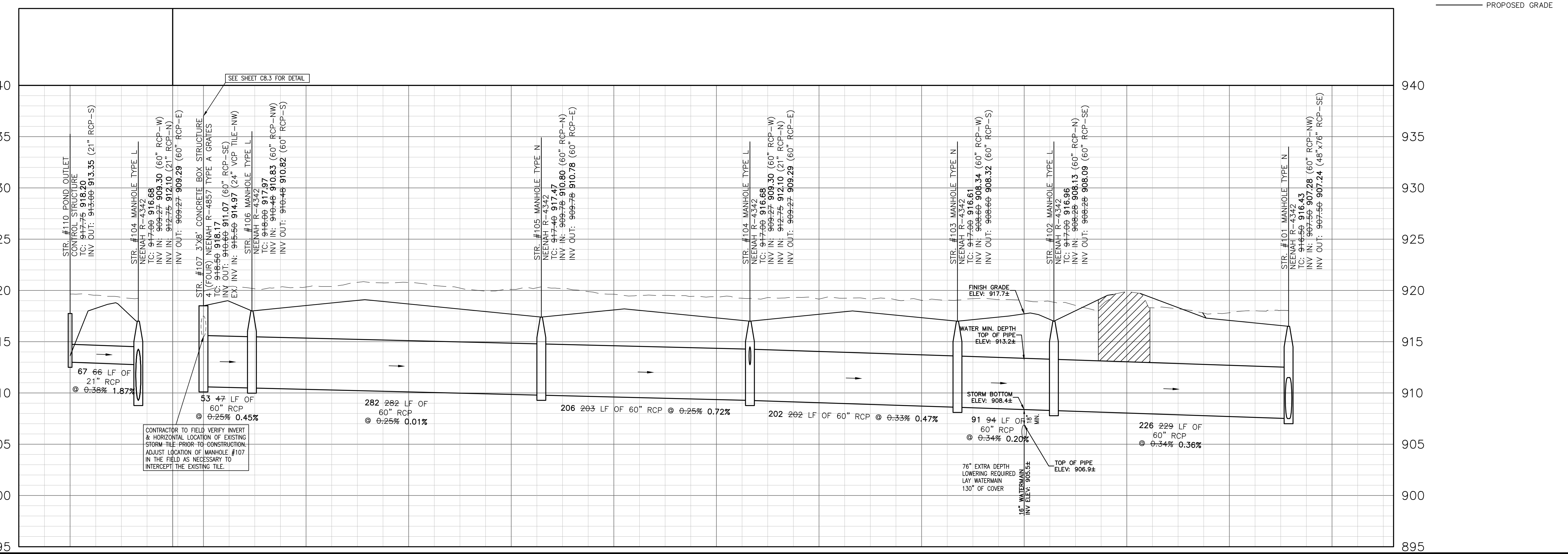

GRANULAR BACKFILL
EXISTING GRADE
PROPOSED GRADE

REVISIONS

DATE	DESCRIPTION	BY
02/25/20	REVISED PER COMMENTS	HM
11/25/20	REVISED STORM OUTLET STR. #103-#844	KS
11/30/20	REVISED STORM OUTLET STR. #101-#844	KS
12/7/20	REVISED STORM OUTLET STR. #102-#845	KS
12/14/20	REVISED STORM OUTLET STR. #101-#100	KS
11/29/21	RECORD DRAWING	TW

HWC ENGINEERING
INDIANAPOLIS - TERRE HAUTE
LAFAYETTE - MUNICE - NEW ALBANY
www.hwcengineering.com

ATWATER SECTION 1
CITY OF WESTFIELD, INDIANA
STORM SEWER PLAN & PROFILE

LUKE A. JAHN
REGISTERED PROFESSIONAL SURVEYOR
No. 20900171
STATE OF INDIANA

DRAWN BY: TD/KS/MEG
CHECKED BY: HM
DATE: JANUARY 3, 2020
SCALE: AS SHOWN
SHEET

C6.0
STORM SEWER PLAN & PROFILE

Plot Date: Dec 20, 2021 Plot Time: 3:29pm File Name: W:\Other Homes\2019-157-A-01thof-A-Atwater Sec 1\Design\CAD\19157-A-Storm Plan - Asbuilt.dwg Layout: C6.0 By: sdonaldson

EXISTING		PROPOSED	
---	RIGHT-OF-WAY LINE	---	RIGHT-OF-WAY LINE
---	EASEMENT LINE	---	EASEMENT LINE
---	SETBACK LINE	---	SETBACK LINE
---	CENTERLINE	---	CENTERLINE
---	SWALE / FLOWLINE	---	SWALE / FLOWLINE
---	SUBSURFACE DRAIN	---	SUBSURFACE DRAIN
---	SANITARY SEWER	---	SANITARY SEWER
---	STORM SEWER	---	STORM SEWER
---	STORM CULVERT	---	STORM CULVERT
---	WATER MAIN	---	WATER MAIN
---	SANITARY MANHOLE	---	SANITARY MANHOLE
---	STORM MANHOLE	---	STORM MANHOLE
---	STORM INLET	---	STORM INLET
---	STORM END SECTION	---	STORM END SECTION
---	FIRE HYDRANT	---	FIRE HYDRANT
---	PROFILED PIPELINE	---	PROFILED PIPELINE
---	RCP - REINFORCED CONCRETE PIPE	---	RCP - REINFORCED CONCRETE PIPE
---	TC - TOP OF CASTING GRADE	---	TC - TOP OF CASTING GRADE

Pipe Table		
UPSTREAM TO DOWNSTREAM	PIPE LENGTH (FT)	PIPE DIA. (IN)
131-130	52	15"
135-134	138	12"
152-151	122	18"
153-152	24	15"
153A-153	10	12"
154-153	31	15"
154A-154	10	12"
155-154	144	12"
156-155	34	12"
174-151	144	12"
174A-174	10	12"
175-174	31	12"
175A-175	10	12"
289-288	26	60"
291-290	19	42"
294-293	145	48"

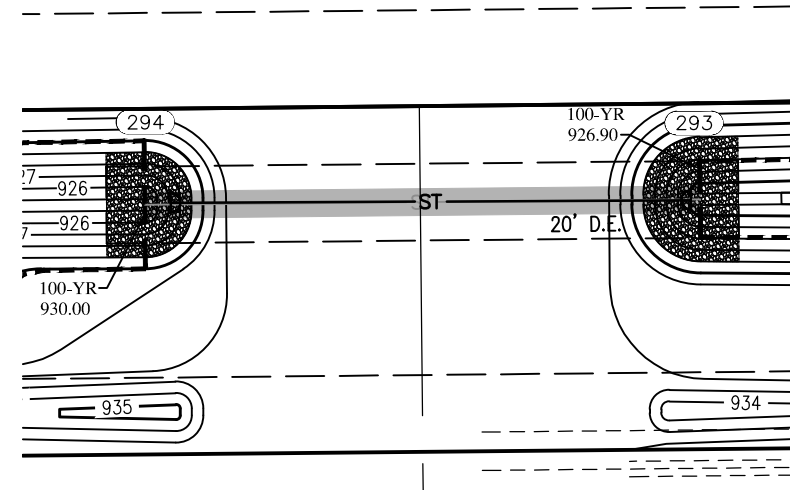

NOTE: SEE SHEET C6.0 FOR BENCHMARK INFORMATION.

STORM SEWER STRUCTURE DATA TABLE									
STR. #	TC	INV. IN (ELEV.)	INV. OUT (ELEV.)	PIPE IN DIA. (INCH)	PIPE OUT DIA. (INCH)	PIPE IN MATERIAL	PIPE OUT MATERIAL	STR. & CASTING TYPE	
130	914.25	913.00 (NE)		15"		RCP		12" CONCRETE END SECTION	
131	920.84	914.35 (NE)	914.15 (SW)	12"	15"	RCP	RCP	INLET TYPE A NEENAH R-4342	
134	914.25	913.00 (NW)		12"		RCP		12" CONCRETE END SECTION	
135	921.00	917.75 (N)	917.65 (SE)	12"	12"	RCP	RCP	INLET TYPE A NEENAH R-4342	
151	925.50	920.14 (E) 921.97 (W)	920.04 (S)	18" 12"	18"	RCP RCP	RCP	MANHOLE TYPE C NEENAH R-4342	
152	926.21	920.56 (E)	920.36 (W)	15"	18"	RCP	RCP	MANHOLE TYPE C NEENAH R-1642	
153	925.70	920.77 (E) 921.70 (S)	920.67 (W)	15" 12"	15"	RCP RCP	RCP	MANHOLE TYPE C NEENAH R-3501-TL	
153A	925.77		921.80 (N)		12"		RCP	INLET TYPE A NEENAH R-3501-TR	
154	925.70	921.04 (E) 921.70 (S)	920.84 (W)	12"	15"	RCP RCP	RCP	MANHOLE TYPE C NEENAH R-3501-TR	
154A	925.77		921.80 (N)		12"		RCP	INLET TYPE A NEENAH R-3501-TL	
155	924.80	921.58 (E)	921.48 (W)	12"	12"	RCP	RCP	INLET TYPE A NEENAH R-4342	
156	925.50		921.69 (W)		12"		RCP	INLET TYPE A NEENAH R-4342	
174	927.37	923.52 (W) 923.52 (S)	923.42 (E)	12" 12"	12"	RCP RCP	RCP	INLET TYPE A NEENAH R-3501-TR	
174A	927.43		923.62 (N)		12"		RCP	INLET TYPE A NEENAH R-3501-TL	
175	927.32	923.72 (S)	923.62 (E)	12"	12"	RCP	RCP	INLET TYPE A NEENAH R-3501-TL	
175A	927.43		923.82 (N)		12"		RCP	INLET TYPE A NEENAH R-3501-TR	
288	919.66	917.60 (N)		60"		RCP		21" CONCRETE END SECTION	
289	925.07		917.70 (S)		60"		RCP	MANHOLE TYPE N NEENAH R-1642	
290	925.56	921.60 (N)		42"		RCP		18" CONCRETE END SECTION	
291	927.78		921.65 (S)		42"		RCP	MANHOLE TYPE K NEENAH R-1642	
293	928.60	924.10 (W)		48"		RCP		48" CONCRETE END SECTION	
294	929.45		924.95 (E)		48"		RCP	48" CONCRETE END SECTION	



Call 811 or 800-382-5544 Before you Dig!

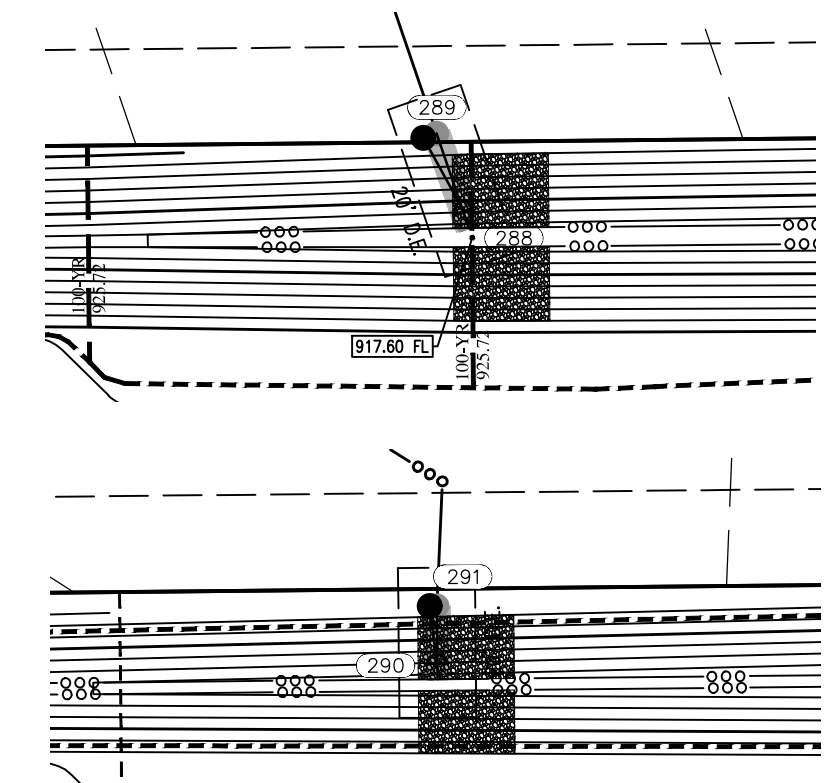
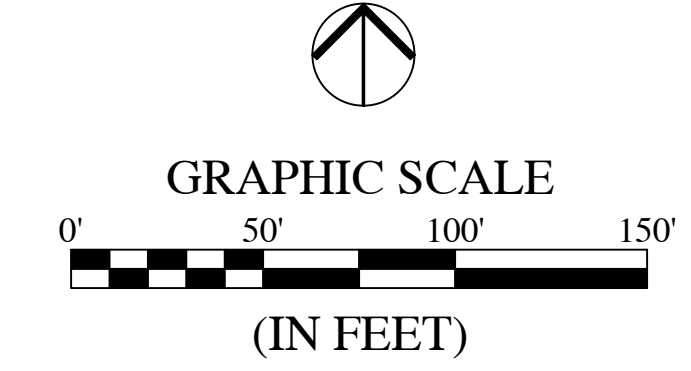

FOR THE FOLLOWING DOUBLE INLET STRUCTURES, SEE DETAIL ON SHEET C8.3:

114-114A	149-149A	172-172A
115-115A	153-153A	174-174A
127-127A	154-154A	175-175A
140-140A	159-159A	179-179A
141-141A	160-160A	180-180A
148-148A	171-171A	

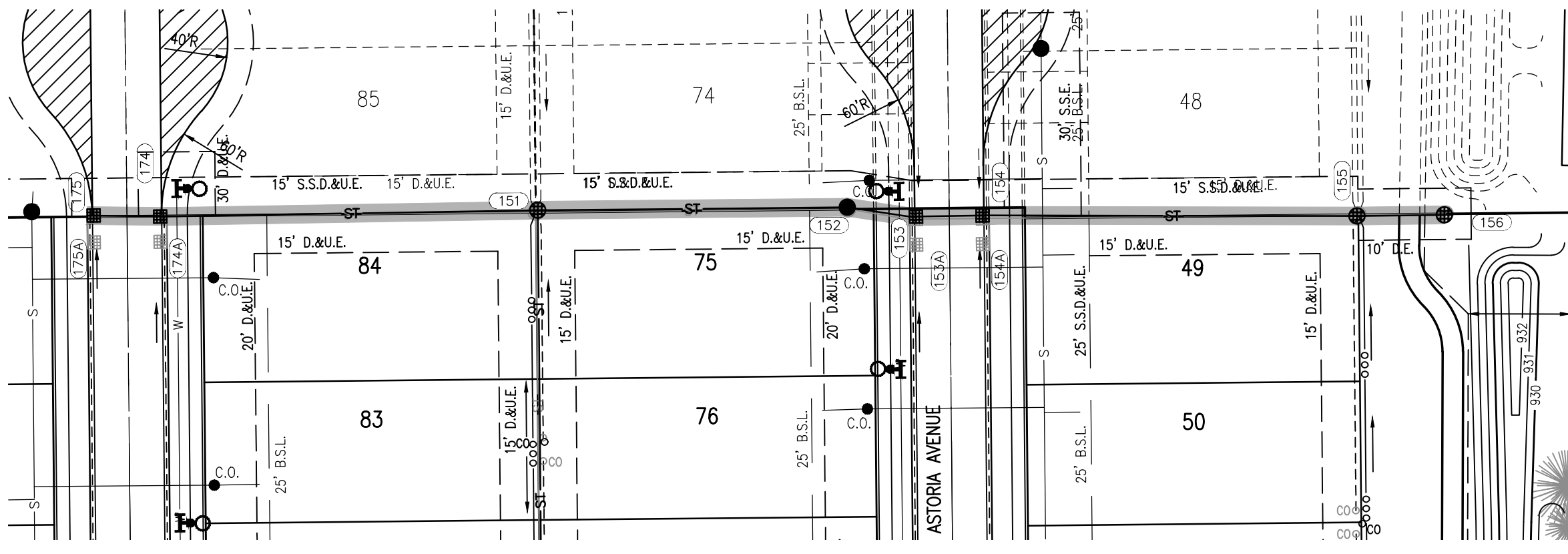
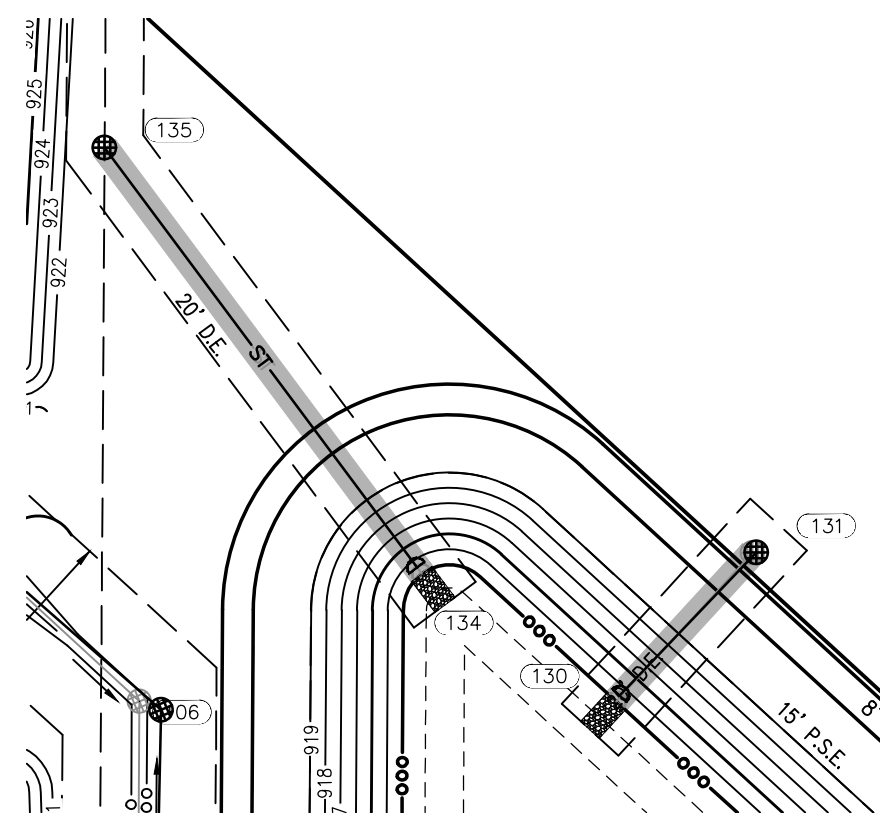

STORM PROFILE
VERTICAL SCALE: 1" = 5'
HORIZONTAL SCALE: 1" = 50'

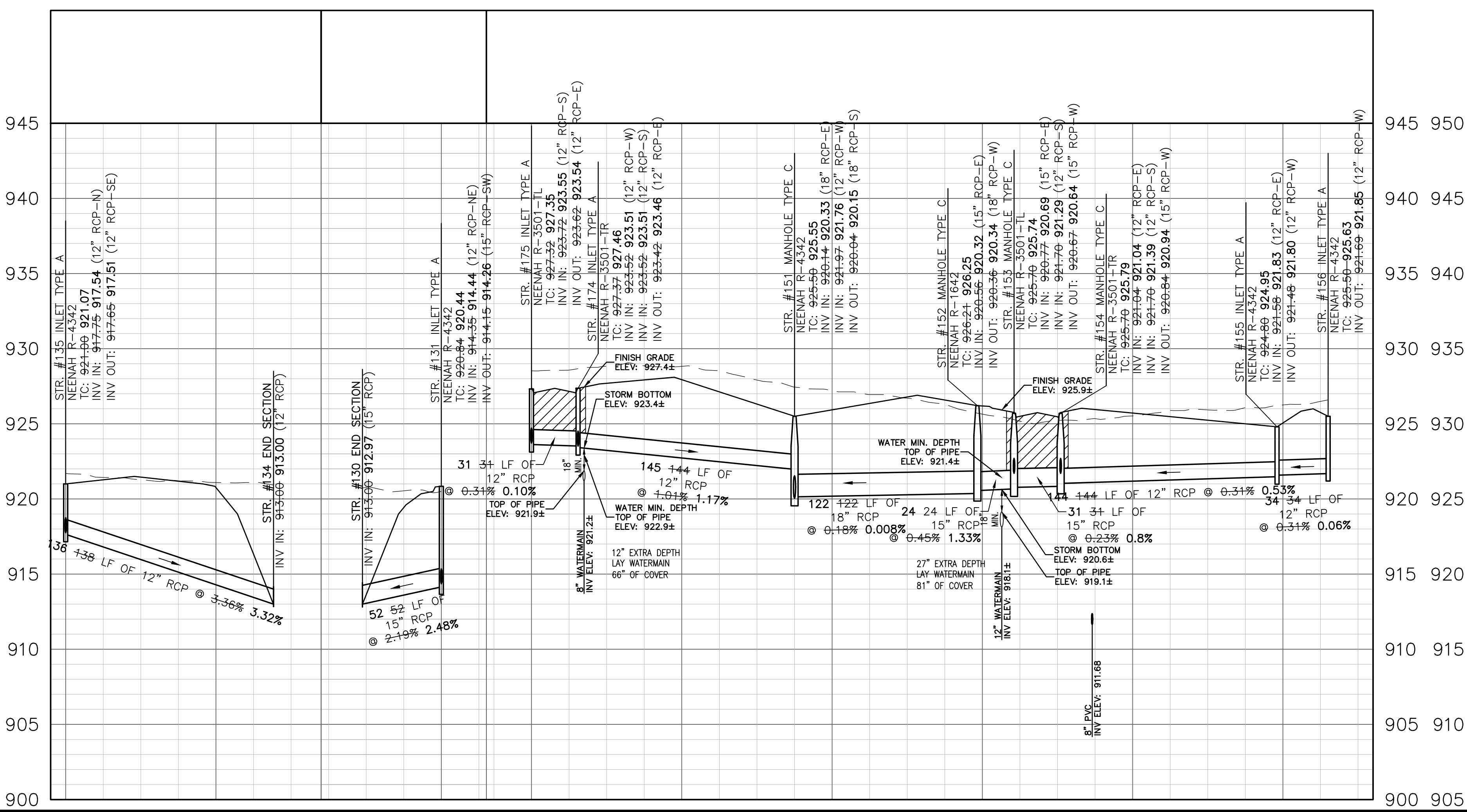

CERTIFICATION FOR "RECORD DRAWING"

CERTIFIED BY: *LUKE A. JAHN*
LUKE A. JAHN
HWC ENGINEERING
135 N. PENNSYLVANIA STREET, SUITE 2800
INDIANAPOLIS, INDIANA 46204
(317) 347-3663 FAX (317) 347-3664

DATE: 12/20/2021

NOTE: Record drawing certification only for top of casting, invert elevations and lengths of pipe. Slope percentage represents a calculated figure and is for general information only.

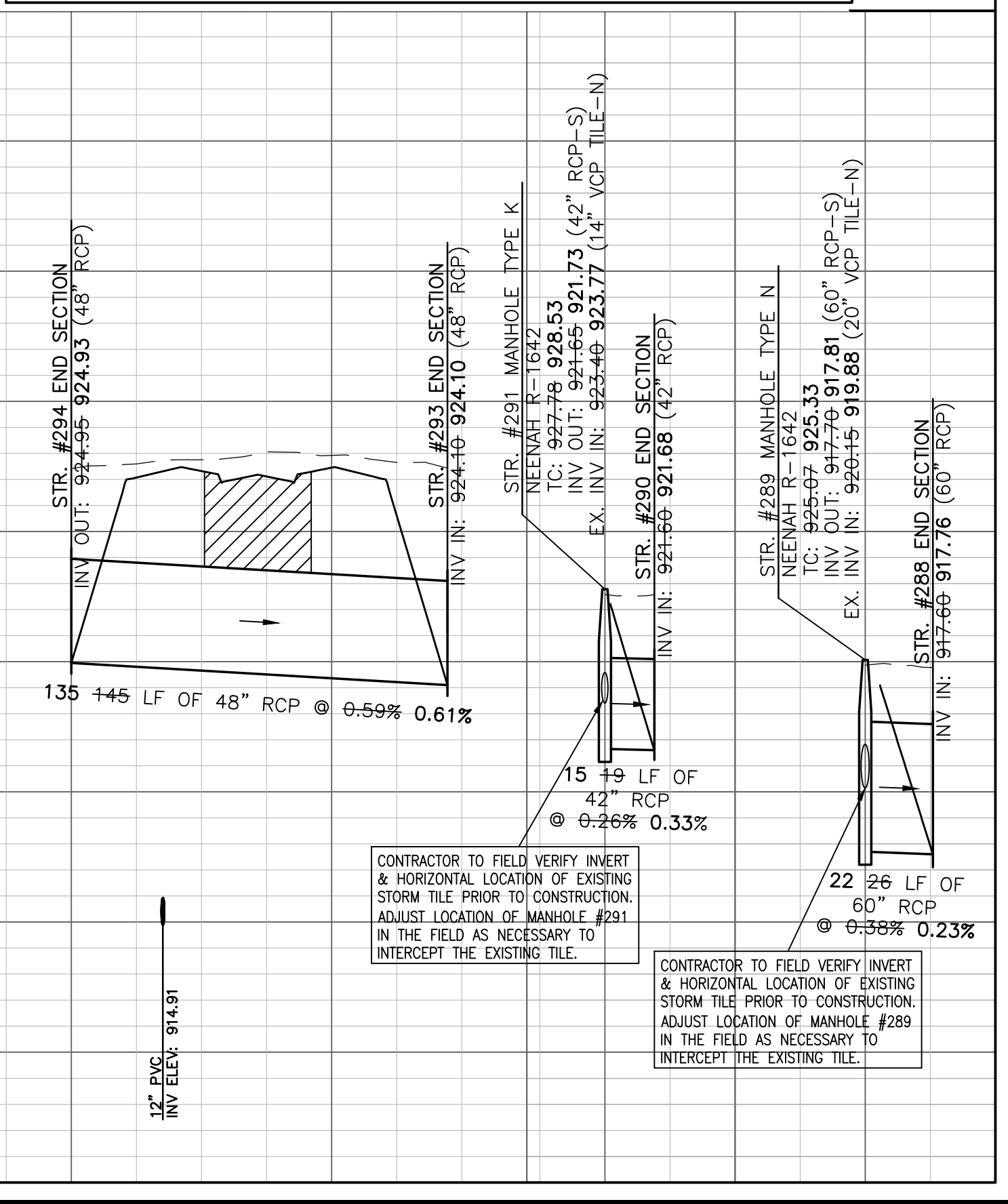
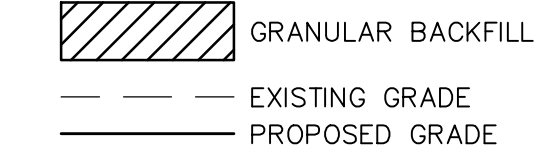
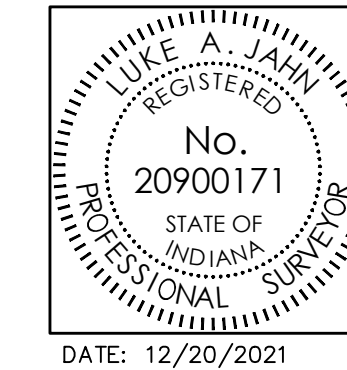

REVISIONS		
DATE	DESCRIPTION	BY
02/25/20	REVISED PER COMMENTS	HM
11/29/21	RECORD DRAWING	TW

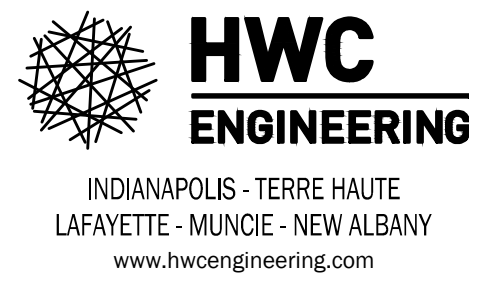

ATWATER SECTION 1
CITY OF WESTFIELD, INDIANA
STORM SEWER PLAN & PROFILE



DRAWN BY: TD/KS/MCG
CHECKED BY: HM
DATE: JANUARY 3, 2020
SCALE: AS SHOWN
SHEET

JOB NUMBER: 2019-157-A

C6.5
STORM SEWER PLAN & PROFILE